



FLUID BED DRYERS, COOLERS AND MOISTURIZERS

*For bulk foods, pharmaceuticals, and chemicals
on a laboratory or production scale*



Self-contained system with circular fluid bed processor

Greater performance in less space at lower cost than ever before possible

Kason fluid bed dryers, coolers, and moisturizers employ an innovative circular processing unit which is inherently stronger, lighter, and less costly to build—and finish to sanitary standards—than rectangular units having equivalent surface area.

Because the circular fluid bed processor is also more compact, complete fluid bed systems can be pre-engineered and pre-configured on caster-mounted frames, ready for installation and start up.

Moreover, Kason circular fluid bed processors maintain an unprecedented level of operating efficiency across a wide range of model sizes—from 18 to 84 inches (450 to 2125 mm) in diameter—for laboratory and pilot plant testing as well as batch or high-volume in-line drying, cooling, or moisturizing of bulk foods, pharmaceuticals, and chemicals.



This pilot-plant-scale drying system incorporates a surge bin, rotary valve, 24" (600 mm) diameter fluid bed processor, heater, blower, and controls on a caster-mounted frame. Processors as small as 18" (450 mm) in diameter are offered for laboratory applications.



With simple connections to an existing dust collector and power source, this fluid bed dryer system is ready to reduce the moisture content of boric acid from 10 to 0.5 percent on a batch basis. It combines a 40" (1000 mm) diameter fluid bed processor, heater, blower, and controller on a caster-mounted skid.



This skid-mounted, turnkey dryer-screener system configures a 48-inch (1225 mm) fluid bed dryer and two-deck circular vibratory screener in series to dry proprietary chemical powder while removing undersize and oversize particles at the rate of 2000 lbs/h (907 kg/h). The screener is equipped with a bulk bag hanger and extended discharge spout to align with the bag intake spout, and magnetic ferrule to remove tramp metal from the finished product prior to packaging.



Moisture content of bulk catalyst is reduced from 9 to 1 percent at a continuous rate of 2000 lbs/h (900 kg/h) with this self-contained drying system. It is comprised of a 48" (1225 mm) fluid bed processor, heater, blower, and cyclone separator, as well as a top-mounted CENTRI-SIFTER® centrifugal screener for continuous de-agglomerating of incoming material.

Principle of operation

Fluid bed processors dry, moisturize, heat, or cool bulk solid material by causing it to vibrate on a screen or perforated surface within a rising column of heated, chilled, or moisturized air.

Continuous air flow and vibration separate and fluidize individual particles, maximizing the surface area of material and, accordingly, the rate at which drying, moisturizing, heating or cooling can occur.

The vibratory motion of the processor also serves to convey the material along a defined pathway for uniform processing on a "first in/first out" basis, and to evacuate the fluid bed at the end of each cycle.

To prevent the uppermost layers of fluid bed particles from being pulled into the exhaust stream, the fluid bed exhaust plenum tapers outward to a larger diameter than that of the fluid bed screen surface, reducing the air velocity. For drying, cooling or moisturizing applications that also require de-dusting of the material, exhaust plenums are cylindrical instead of tapered, causing dust to be drawn from the fluid bed chamber to a dust collection device. (Detail next page)

To fit your material application and integrate with existing plant equipment, Kason offers a comprehensive range of equipment available as components, sub-systems, or complete systems as described at bottom.

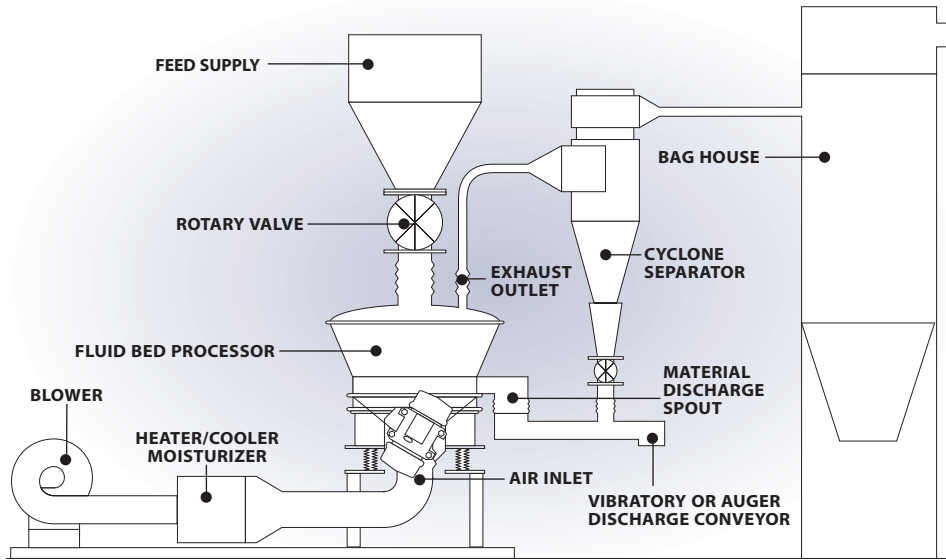

Supply side components:

- Centrifugal fans
- Air filters
- Electric heaters
- Oil- or gas-fired heaters
- Steam coils
- Water chillers/heat exchangers
- Humidifiers
- Ductwork and valves
- Air flow meters and automated controls

Fluid bed components:

- Storage bin with bin activator and rotary valve
- Vibratory or auger feeder (unnecessary when storage bin is positioned above fluid bed processor)
- Vibratory fluid bed processor including intake and exhaust plenums, flexible couplings, quick-disconnect cowl, circular screen, eccentric motor drives, and spring suspension
- Vibratory, auger, or pneumatic discharge conveyor
- Level sensors and automated controls

Exhaust-side components:

- Ductwork
- Cyclone separator with rotary valve
- Bag house with exhaust blower

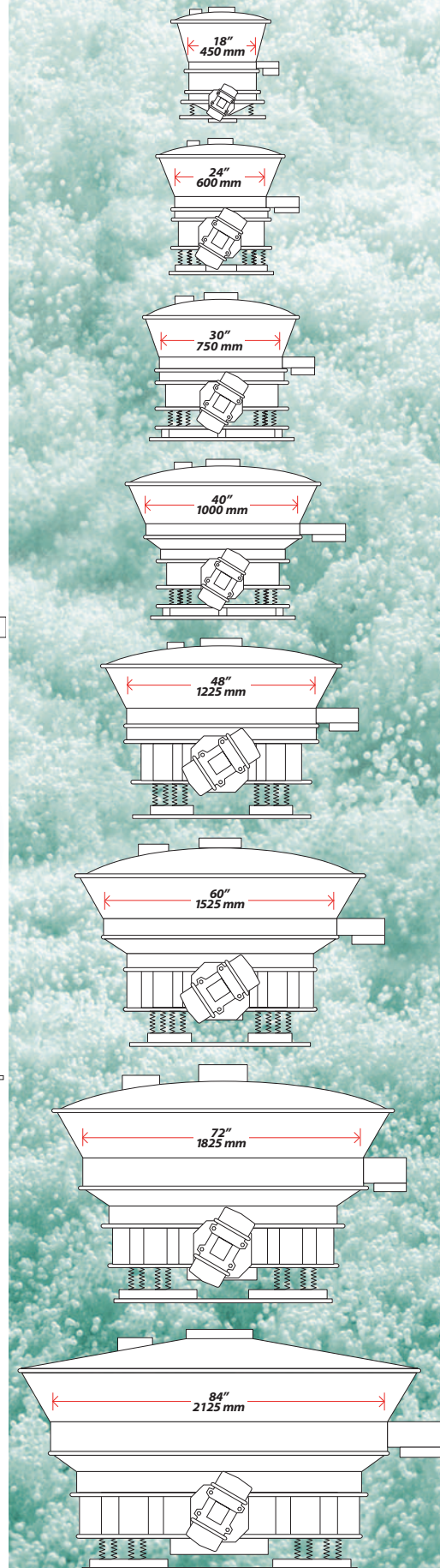

De-dust, scalp, de-agglomerate, or agglomerate while fluid bed processing

Configurations and accessories are available for scalping, de-dusting or de-agglomerating of materials while they are dried, cooled or moisturized, reducing or eliminating the initial and operating cost of separate equipment.

Kason Fluid Bed Processors are also effective at agglomerating of bulk materials independent of or in conjunction with, drying, cooling or moisturizing operations as described below.

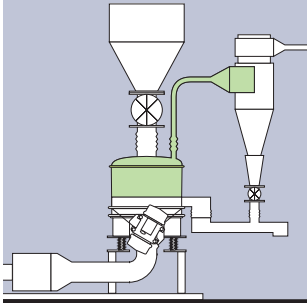

DE-DUSTING

For drying, cooling or moisturizing applications that also require de-dusting of the material, cylindrical exhaust plenums can be specified (instead of tapered plenums that reduce air speed), causing fluidized dust to be drawn from the fluid bed chamber into a cyclone or other dust collection device, eliminating the need for a separate de-dusting screener.

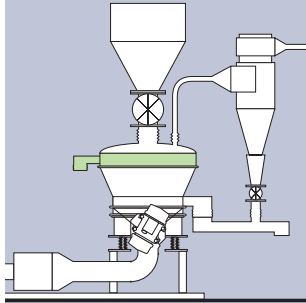

SCALPING

For scalping of oversize particles from material before it is dried, cooled or moisturized, the fluid bed chamber can be fitted with an integral, top-mounted screening deck that derives its vibratory motion from the fluidizing chamber's gyratory motors, significantly undercutting the initial and operating costs of a stand-alone screener, while preserving floor space.

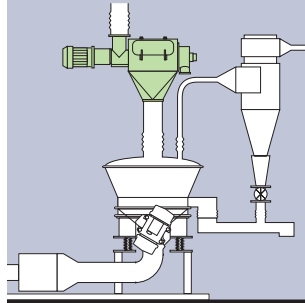

DE-AGGLOMERATING

Many materials that require fluid bed processing tend to form agglomerates that can reduce drying/cooling/moisturizing efficiency and/or uniformity of the finished product. In these instances, Kason fluid bed systems can be equipped with integral CENTRI-SIFTER® centrifugal screeners for continuous de-agglomerating of incoming material. (Far left page, bottom right).

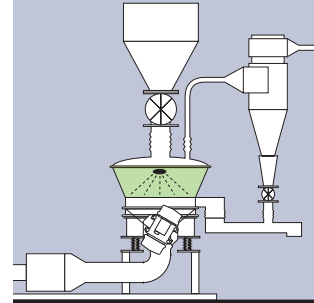

AGGLOMERATING

Kason Fluid Bed Agglomerators employ a spraying system within the fluid bed chamber that introduces moisture to powdered material as it is fluidized, causing particles to form agglomerates on a controlled basis. Fluid bed drying, cooling or moisturizing can be employed concurrently to condition the material, maximizing physical characteristics of the agglomerates as well as production efficiency.

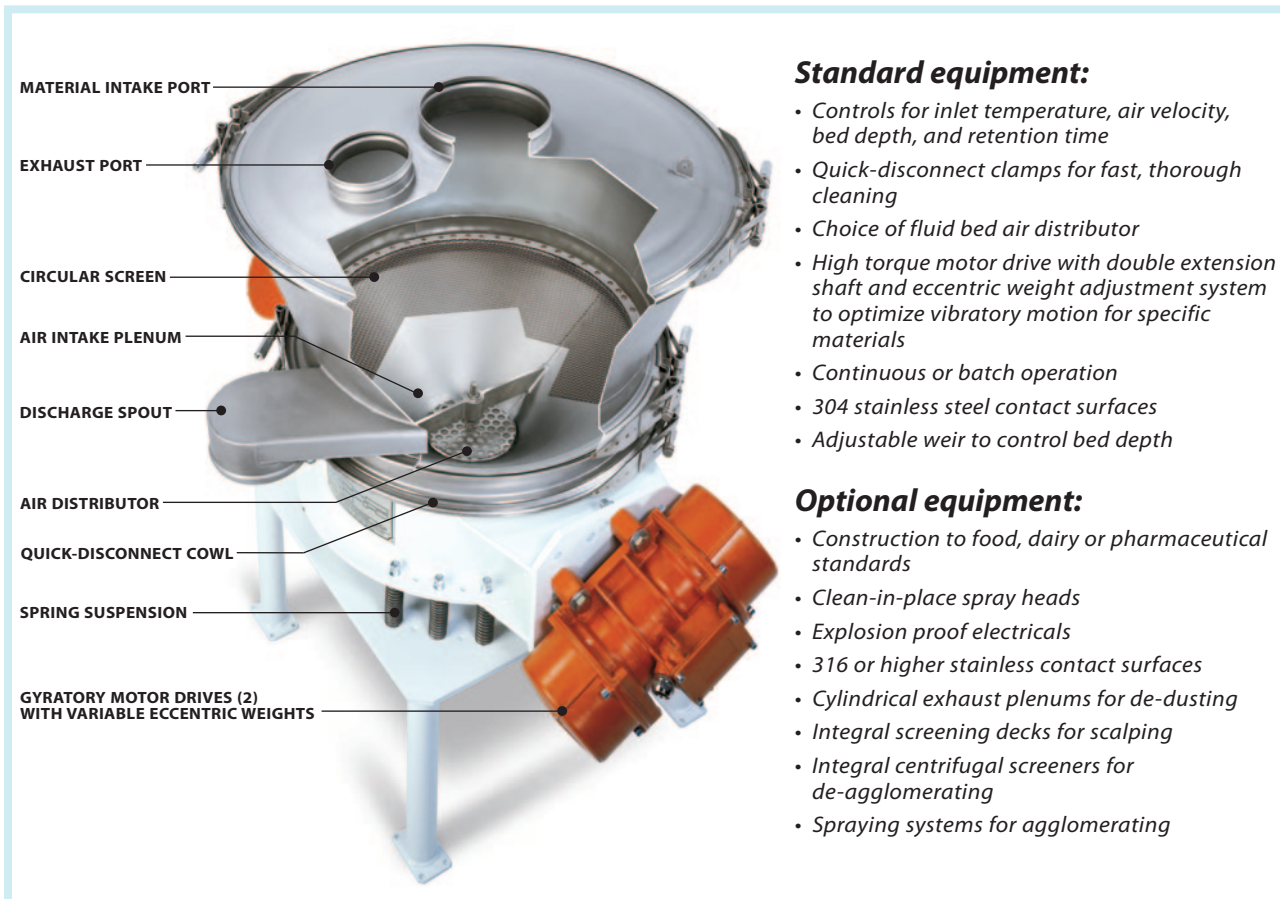

- MATERIAL INTAKE PORT
- EXHAUST PORT
- CIRCULAR SCREEN
- AIR INTAKE PLENUM
- DISCHARGE SPOUT
- AIR DISTRIBUTOR
- QUICK-DISCONNECT COWL
- SPRING SUSPENSION
- GYRATORY MOTOR DRIVES (2) WITH VARIABLE ECCENTRIC WEIGHTS

Standard equipment:

- Controls for inlet temperature, air velocity, bed depth, and retention time
- Quick-disconnect clamps for fast, thorough cleaning
- Choice of fluid bed air distributor
- High torque motor drive with double extension shaft and eccentric weight adjustment system to optimize vibratory motion for specific materials
- Continuous or batch operation
- 304 stainless steel contact surfaces
- Adjustable weir to control bed depth

Optional equipment:

- Construction to food, dairy or pharmaceutical standards
- Clean-in-place spray heads
- Explosion proof electricals
- 316 or higher stainless contact surfaces
- Cylindrical exhaust plenums for de-dusting
- Integral screening decks for scalping
- Integral centrifugal screeners for de-agglomerating
- Spraying systems for agglomerating

Circular fluid bed processor outperforms traditional rectangular configurations



Higher strength-to-weight ratio

Inherently rigid, a Kason circular fluid bed processor does not require heavy steel sidewalls or cross braces to withstand extensive vibration.

Smaller size range

Eight models range in diameter from 18 to 84 inches (450 to 2125 mm) offering efficient performance across a range of small to moderate volume applications not satisfied by rectangular units.

Kason offers free laboratory testing and/or rentals of fluid bed equipment for pilot plant testing.

The Kason test laboratory is equipped with fluid bed dryers, coolers and moisturizers as well as de-screening, agglomerating and de-agglomerating equipment that are readily configured to simulate custom engineered systems integrated with your new or existing process.

Using customer-supplied material, Kason laboratory technicians,

Lower sanitary construction cost

A Kason circular fluid bed processor uses a lighter gauge shell and components, with fewer weld seams, and requires only one air inlet and outlet resulting in lower material and labor costs—especially when finished to food, dairy, or pharmaceutical standards.

Faster, easier set up

Compact and lightweight, a complete Kason circular fluid bed system can be frame-mounted with casters for low cost shipping, easy installation, and in-plant mobility.

applications engineers and visitors can verify system performance prior to equipment fabrication.

In addition, Kason frequently rents fluid bed equipment for pilot plant testing, enabling customers to engineer entire processes in which drying, cooling or moisturizing is an integral part.

Reduced engineering time

Kason self-contained fluid bed systems are lab tested using your material, engineered, and configured on a frame to ensure on-spec performance as delivered.

Faster, easier cleaning

With no internal cross members, fewer seams and corners, and a quick disconnect shell, a Kason circular fluid bed processor cuts cleaning time dramatically.



The Kason test laboratory controls and monitors all processing variables, optimizing equipment configurations according to each customer's materials and application parameters.



**VIBROSCREEN®
FLO THRU**
Vibratory Screeners
with Air-Lift Device



VIBROSCREEN®
Portable Batch Sifters



VIBROSCREEN®
High-Capacity Classifiers



**VIBROSCREEN®
FLO-THRU Low-Profile,
High-Capacity Vibratory
Screeners**



VIBROSCREEN®
Bag Dump Screening
Stations



**VIBROSCREEN®
PNEUMATI-SIFTER**
High-Capacity Screeners



**VIBROSCREEN®
PNEUMATI-SIFTER
FLO-THRU Ultra-High-
Capacity Screeners**



VIBROSCREEN®
Internal Recycle KASCADE
Screening Decks



**CENTRI-SIFTER®
QUICK-CLEAN**
Centrifugal Screeners



CENTRI-SIFTER®
Centrifugal Dewatering
Screeners



**CENTRI-SIFTER®
PNEUMATI-SIFTER**
Centrifugal Screeners



**CENTRI-SIFTER®
QUICK-CLEAN**
Miniature Screeners

KASON CORPORATION
67-71 East Willow Street
Millburn, NJ 07041-1416
USA
Tel: 973-467-8140
Fax: 973-258-9533
E-mail: info@kason.com

KASON CORPORATION, EUROPE
Units 12 & 13
Park Hall Business Village
Park Hall Road, Longton
Stoke-On-Trent ST3 5XA
UNITED KINGDOM
Tel: (0) 1782 597540
Fax: (0) 1782 597549
E-Mail: sales@kasoneurope.co.uk

SEPARATOR ENGINEERING LTD.
2220 Midland Avenue, #85
Scarborough, Ontario M1P 3E6
CANADA
Tel: 416-292-8822
Fax: 416-292-3882
E-Mail: info@separatorengineering.com

www.kason.com



● Manufacturing Facilities
● Representative Locations

